

ELECTRICAL SPECIFICATION

ITEM	DESCRIPTION	CAPACITY
1	POWER SUPPLY*	220 VAC - 380 VAC - 440 VAC / 3P
2	POWER RANGE	3 kW to 15 kW

*More options on demand

FLOW CAPACITY

ITEM	DESCRIPTION	CAPACITY
1	DESIGNED FLOW RANGE	20 m3/h to 80 m3/h
2	MAXIMUM PRESSURE SYSTEM	4.5 bar
3	BOOSTER PUMP SPECIFICATION	20 m3/h - 5 bar

DOSING CHANNELS

ITEM	DESCRIPTION	CAPACITY
1	NUMBER OF DOSING CHANNELS	5
2	VENTURI + FLOWMETER*	50 - 650 lts/hr.

*Optional use of digital or magnetic flowmeter

PREMIX TANK

ITEM	DESCRIPTION	CAPACITY
1	PREMIX TANK. MATERIAL: HDPE DIMENSIONS: 1400mm x 645mm x 600mm	400 L

EQUIPMENT DESCRIPTION

ITEM	FEATURES
1	Independently controlled, 5-way automatic injection system.
2	Control and monitoring of pH sensor and EC sensor. *
3	Dosing actuators 24VDC NC Valves.**
4	Pumps controlled by variable frequency drives.
5	Real-time recording of consumption through magnetic measurements.***
6	Monitor App on Google Play, Apple Store and Web App.

*Optional use 2 pH sensor and 2 EC sensor.

**Different alternatives.

***Applies in case of digital flowmeter.

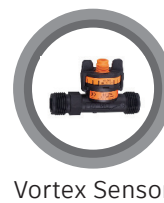
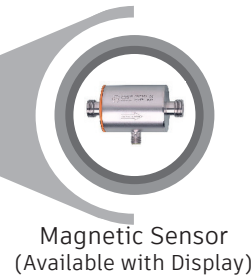

- ENERGY OPTIMIZATION
- WATER MANAGEMENT
- CLIMATE INTEGRATION
- DATA MANAGEMENT
- SUSTAINABILITY
- IoT & SMART FARMING COMPATIBLE

Cabinet is available in this colors:



*OEM/Custom preference

All rights reserved by iSinitzan. Reproduction and distribution of any part of this document is prohibited.



DIMENSIONS & FOOTPRINT

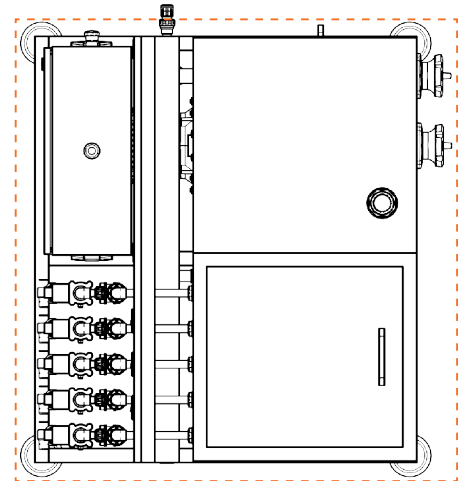
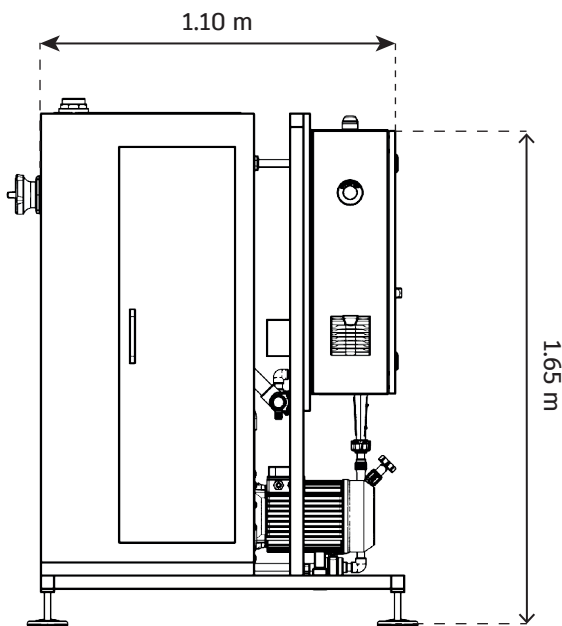
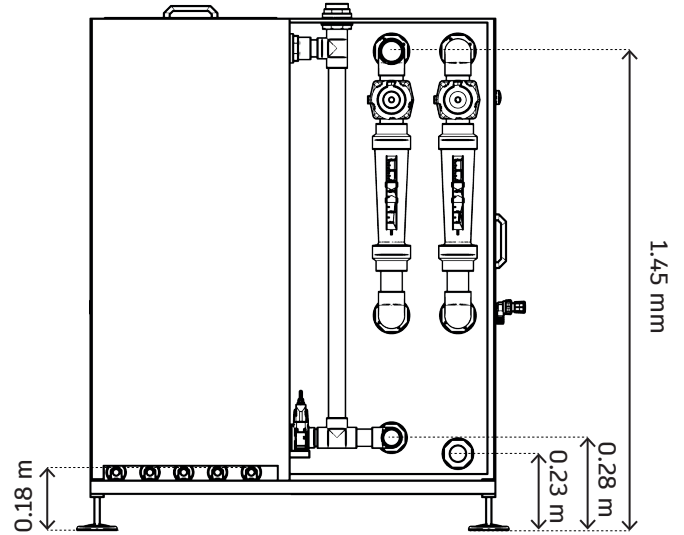
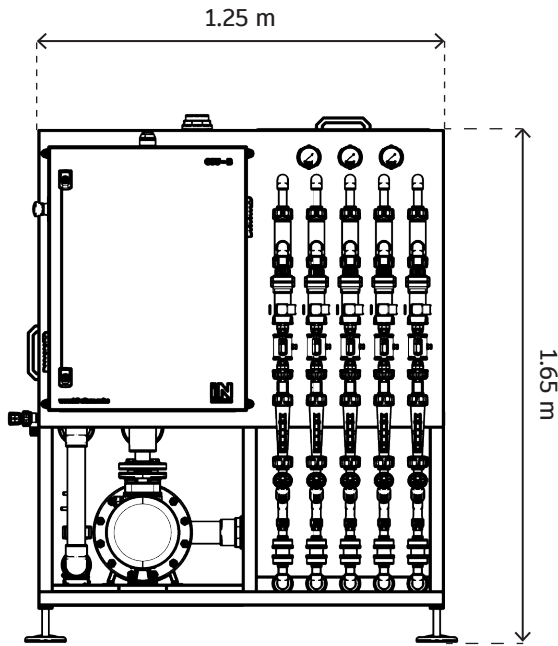

Footprint: 1.55 m²

Note:
 - All 3D file drawing (.step, .dwg) are available.
 - The prices shown in the price list are valid from August 2023. They may be modified according to changes in materials and manufacturing accessories.

DIMENSIONS		
LENGTH	HEIGHT	WIDTH
1,25 m	1,65 m	1,10 m
FOOT PRINT		1,55 m ²

All rights reserved by iSinitzan. Reproduction and distribution of any part of this document is prohibited.

iSii-Nitzan GmbH
 Via Cremignone 4C, Sorengo,
 Switzerland, CH 6924
 +(41) 765851837
 info@isii-nitzan.swiss
 www.isii-nitzan.swiss

More Information:



Versión: J2024-1