

KLIN - SAND FILTER



ITEM TECHNICAL CHARACTERISTICS

- 1 HIGH-QUALITY CARBON STEEL ST37.2 ENSURES ROBUST CONSTRUCTION
- 2 ROBUST MATERIALS MINIMIZE NEED FOR FREQUENT REPLACEMENTS
- 3 UNINTERRUPTED OPERATION DURING FILTRATION AND BACKFLUSHING
- 4 SPECIAL TREATMENT WITH SAND-BLASTING AND TWO-LAYER COATING
- 5 FLOW RATES AND INSTALLATION CONSTRAINTS
- 6 MODULAR MANIFOLDS ALLOW SIMPLE ASSEMBLY AND EXPANSION
- 7 ENHANCING VERSATILITY AND SCALABILITY
- 8 LONG-TERM RELIABILITY
- 9 RESILIENT AGAINST AGRICULTURAL ENVIRONMENT STRESSORS

HEAD LOSS FLOW RATE

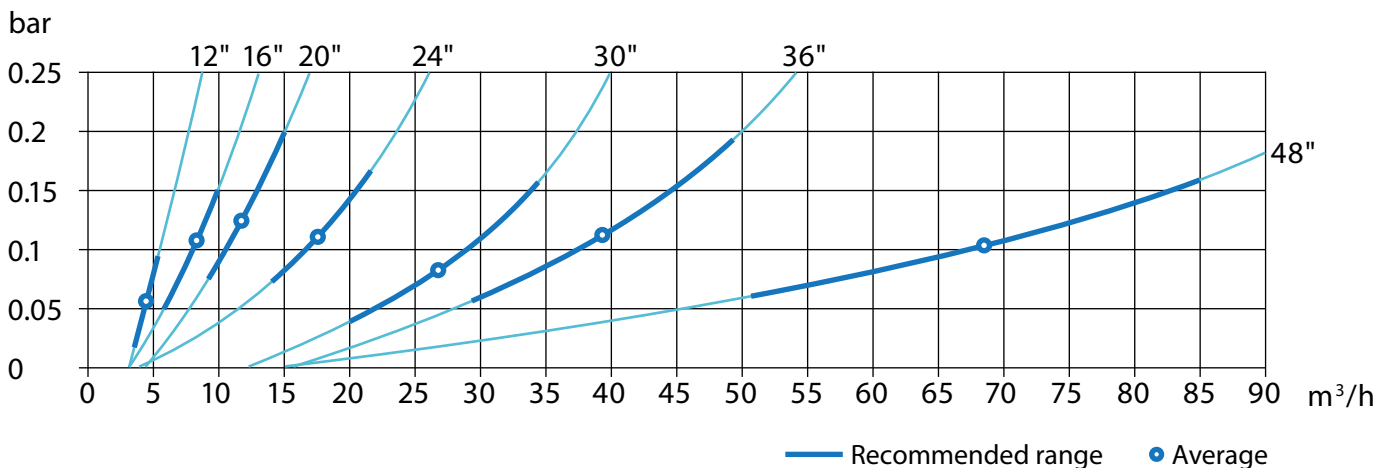

DIMESIONS

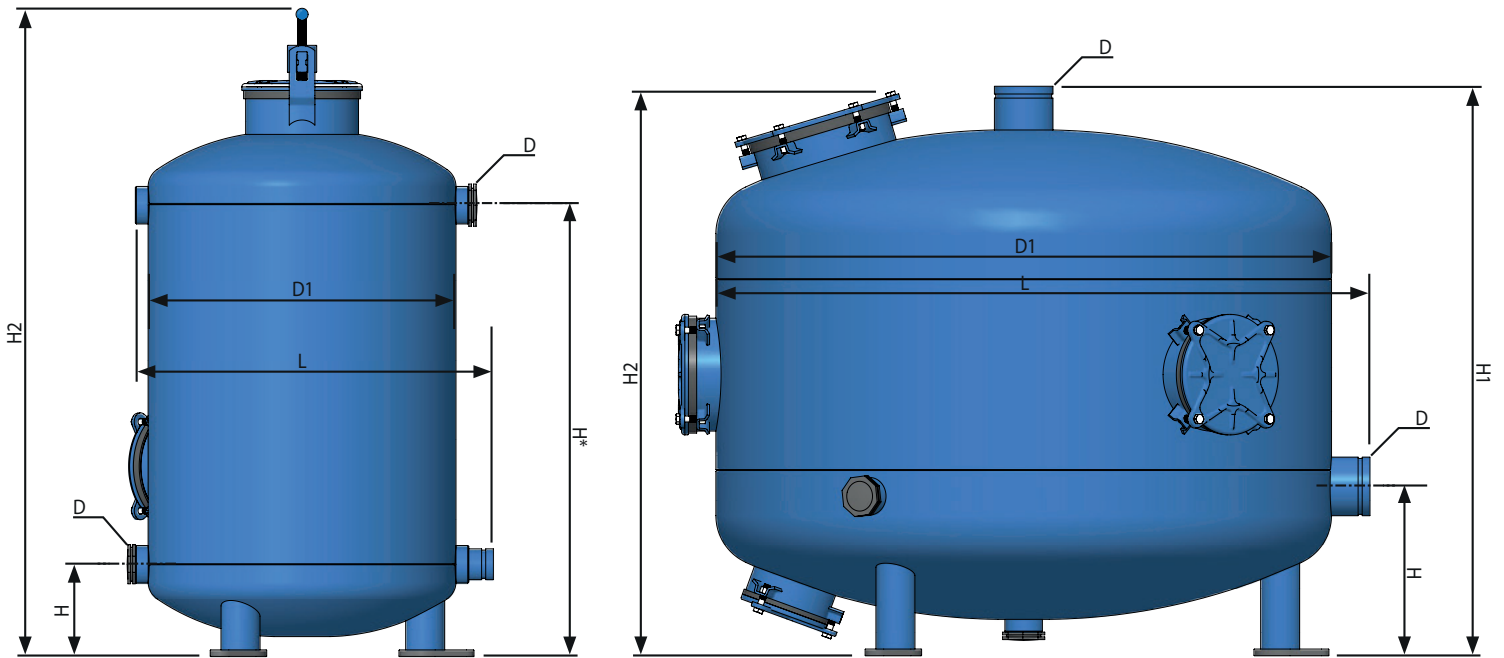

| TANK | D [in] | D1 [in] | AREA | FLOW RATE | BACK FLUSH | H1 | H2 | H | L | WIEGHT [kg] | SAND [kg] |
|------|--------|---------|------|-----------|------------|-----|------|------|------|-------------|-----------|
| 12" | 1 | 12 | 0 | 3.5-6 | 7 | 150 | 785 | 1094 | 419 | 45 | 60 |
| 16" | 2 | 16 | 0 | 6-10 | 10 | 180 | 870 | 1198 | 518 | 60 | 90 |
| 20" | 2 | 20 | 0 | 9-15 | 16 | 180 | 880 | 1251 | 614 | 75 | 120 |
| 24" | 2 | 24 | 0 | 13-22 | 22 | 180 | 880 | 1264 | 714 | 110 | 180 |
| 30" | 3 | 30 | 0 | 20-35 | 36 | 300 | 1071 | 1071 | 836 | 120 | 240 |
| 36" | 3 | 36 | 1 | 30-50 | 50 | 300 | 1110 | 1110 | 970 | 160 | 360 |
| 48" | 4 | 48 | 1 | 50-85 | 80 | 300 | 1110 | 1110 | 1353 | 275 | 575 |

